

# RS5 T13 - SETUP SHEET

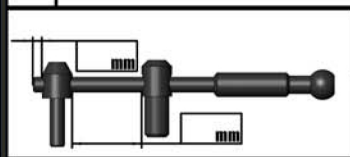

Name \_\_\_\_\_ Track/Air temp \_\_\_\_\_  
 Track \_\_\_\_\_ Condition \_\_\_\_\_  
 Date \_\_\_\_\_ Event/Result \_\_\_\_\_

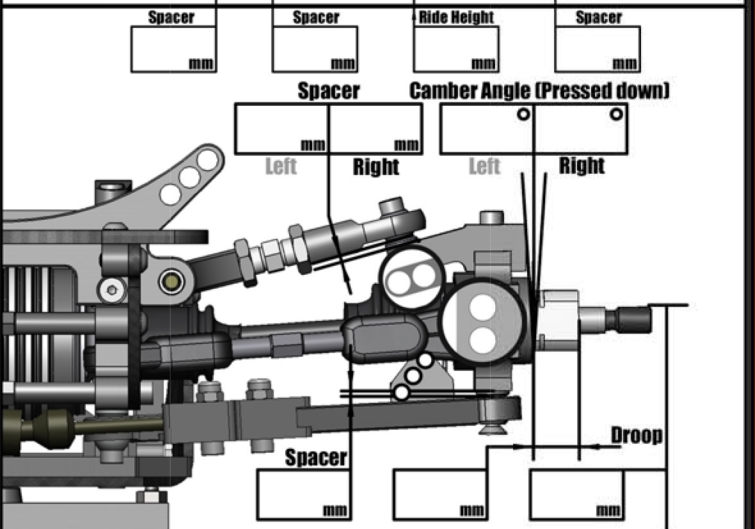
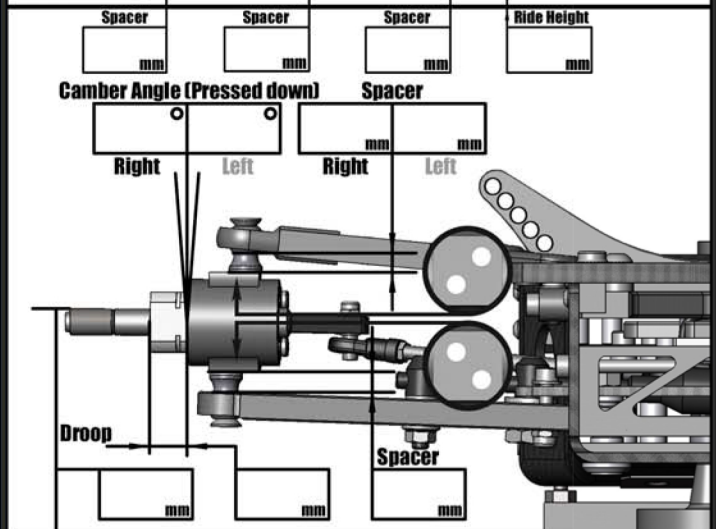
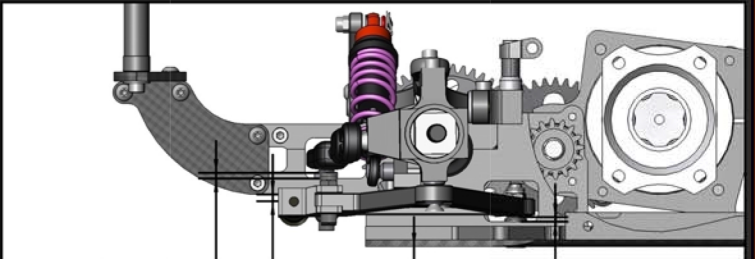

**Front hub offset:**  
 3mm  6mm  
**Bump steering position:**  
 Bottom  Middle  Top

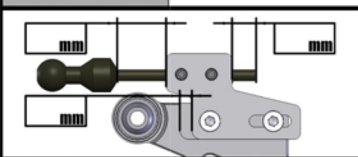

**Comments:**

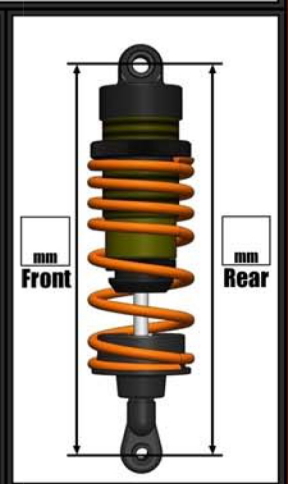
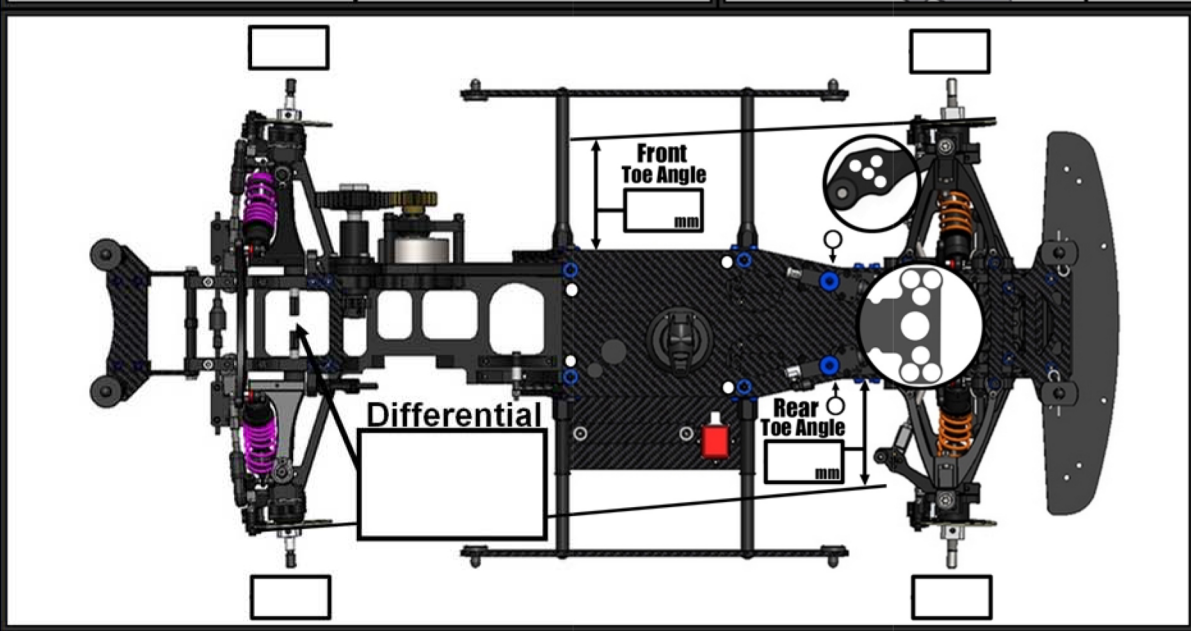

**Oil**  
**Spring**  
 Front Yellow   Yellow  
 Orange   Orange  
 Purple   Purple

<input type="radio"/> 48	<input type="radio"/> 15	<input type="radio"/> 41	<input type="radio"/> 23	<input type="radio"/> 5,71	<input type="radio"/> 48	<input type="radio"/> 16	<input type="radio"/> 41	<input type="radio"/> 24	<input type="radio"/> 5,13	<b>Engine</b>
<input type="radio"/> 48	<input type="radio"/> 15	<input type="radio"/> 40	<input type="radio"/> 23	<input type="radio"/> 5,56	<input type="radio"/> 48	<input type="radio"/> 15	<input type="radio"/> 40	<input type="radio"/> 25	<input type="radio"/> 5,12	<b>Oil</b>
<input type="radio"/> 48	<input type="radio"/> 15	<input type="radio"/> 41	<input type="radio"/> 24	<input type="radio"/> 5,46	<input type="radio"/> 48	<input type="radio"/> 16	<input type="radio"/> 39	<input type="radio"/> 23	<input type="radio"/> 5,08	<b>Exhaust</b>
<input type="radio"/> 48	<input type="radio"/> 15	<input type="radio"/> 39	<input type="radio"/> 23	<input type="radio"/> 5,42	<input type="radio"/> 48	<input type="radio"/> 16	<input type="radio"/> 40	<input type="radio"/> 24	<input type="radio"/> 5,01	<b>Airbox</b>
<input type="radio"/> 48	<input type="radio"/> 16	<input type="radio"/> 41	<input type="radio"/> 23	<input type="radio"/> 5,34	<input type="radio"/> 48	<input type="radio"/> 15	<input type="radio"/> 39	<input type="radio"/> 25	<input type="radio"/> 4,99	<b>Clutch</b> rpm
<input type="radio"/> 48	<input type="radio"/> 15	<input type="radio"/> 40	<input type="radio"/> 24	<input type="radio"/> 5,33	<input type="radio"/> 48	<input type="radio"/> 16	<input type="radio"/> 41	<input type="radio"/> 25	<input type="radio"/> 4,92	<b>Body</b>
<input type="radio"/> 48	<input type="radio"/> 15	<input type="radio"/> 41	<input type="radio"/> 25	<input type="radio"/> 5,24	<input type="radio"/> 48	<input type="radio"/> 16	<input type="radio"/> 39	<input type="radio"/> 24	<input type="radio"/> 4,87	<b>Wing</b>
<input type="radio"/> 48	<input type="radio"/> 16	<input type="radio"/> 40	<input type="radio"/> 23	<input type="radio"/> 5,22	<input type="radio"/> 48	<input type="radio"/> 16	<input type="radio"/> 40	<input type="radio"/> 25	<input type="radio"/> 4,81	<b>Steering Servo</b>
<input type="radio"/> 48	<input type="radio"/> 15	<input type="radio"/> 39	<input type="radio"/> 24	<input type="radio"/> 5,21	<input type="radio"/> 48	<input type="radio"/> 16	<input type="radio"/> 39	<input type="radio"/> 25	<input type="radio"/> 4,68	<b>Gas/Brake Servo</b>

**Comments:**